

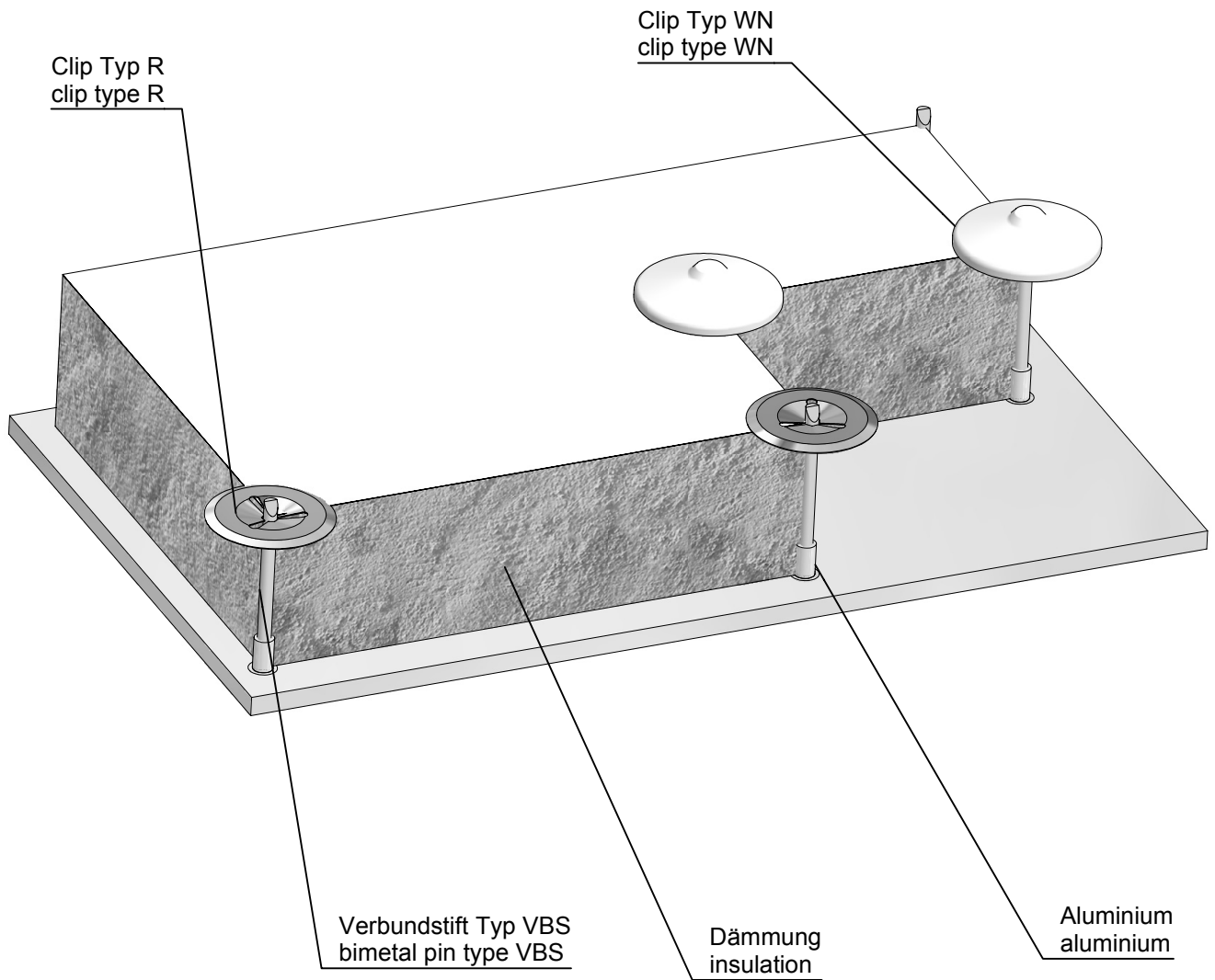

Verbundstift Typ VBS
für Aluminiumkonstruktion

Bimatal pin type VBS
for aluminium construction





Verbundstift Typ VBS
für Aluminiumkonstruktion

Bimetal pin type VBS
for aluminium construction

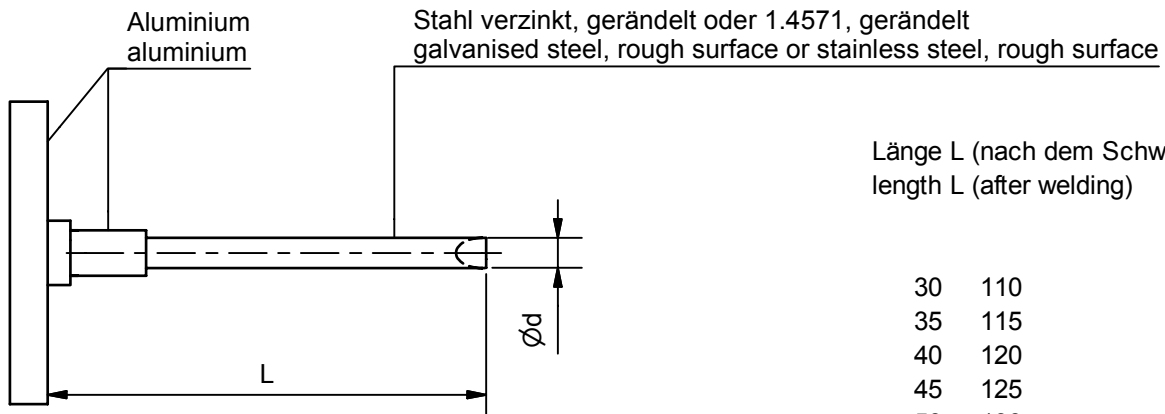

Länge L (nach dem Schweißen)
length L (after welding)

30	110
35	115
40	120
45	125
50	130
55	135
60	140
65	165
70	185
75	205
80	245
85	
90	
95	
100	
105	

Standarddurchmesser:
3,4 und 5 mm

Material:
-Stahl, verzinkt(Standard), gerändelt
-Chrom-Nickel-Stahl (1.4571), gerändelt

Weitere Materialien und Abmessungen
auf Anfrage

standard diameter:
3,4 and 5 mm

material:
-steel galvanised (standard), rough surface
-stainless steel (1.4571), rough surface

other materials or dimensions
on request