

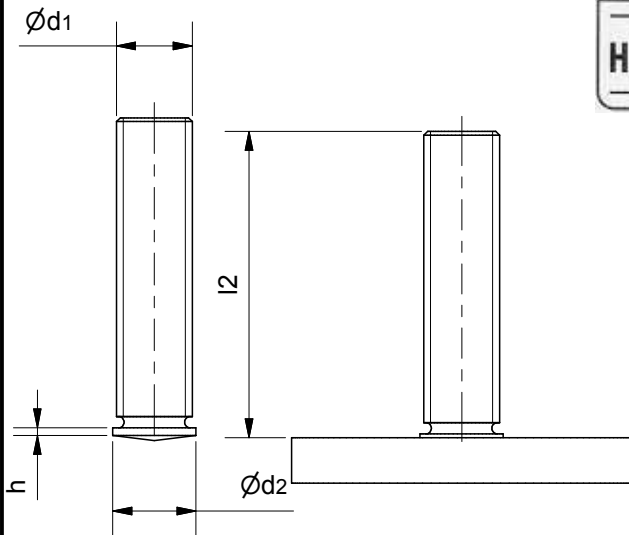

Typ/type PS DIN EN ISO 13918
Gewindebolzen mit Flansch
threaded stud with flange



d1	l2	d2	h	Artikel Nr. ² part.no. ²	Austrüstung ³ tool set ³	Bolzenhalter chuck
M6	25	7	0,8-1,4	H14640	H11727	H10610
M6	30	7	0,8-1,4	H14609	H11727	H11589
M6	40	7	0,8-1,4	H14813	H11727	H11589
M6	50	7	0,8-1,4	H14705	H11727	H11589
M6	80/60	7	0,8-1,4	H14706	H11727	H11589
M8	20	9	0,8-1,4	H13495	H11727	H10611
M8	30	9	0,8-1,4	H15427	H11727	H10611
M8	40	9	0,8-1,4	H15428	H11727	H11152
M8	50	9	0,8-1,4	H14565	H11727	H11152
M8	80/60	9	0,8-1,4	H14566	H11727	H11152
M10	20	RD	3	H14598	H11727	H10924
M10	25	12	3	H14437	H11727	H10924
M10	30	12	3	H15017	H11727	H10924
M10	40	12	3	H11488	H11727	H35126
M10	60	12	3	H15652	H11727	H35305
M10	80	12	3	H14074	H11727	H35305
M10	150/50	12	3	H13399	H11727	H12332
M10	150/140	12	3	H16419	H11727	H12332
M12	40	14	0,8-1,4	H14316	H11727	H10613
M12	50	14	0,8-1,4	H16403	H11727	H10613

² AlMg (Aluminium)

² AlMg (aluminium)

³ Pistolenausüstung K22

³tool set K22

Weitere Materialien und Abmessungen auf
Anfrage

other materials or dimensions on
request

Stammhaus / Headquarter Hilbig GmbH - Großmooring 8 - 21079 Hamburg - phone + 49 40 / 769 210-0 - fax + 49 40 / 769 210-21
Zweigbetrieb / Branch Hechtskuhl 17 - 23992 Neukloster - phone + 49 38422 / 423-0 - fax + 49 38422 / 423-13
Internet: www.hilbig-gmbh.de - email: info@hilbig-gmbh.de