



Rutschsicherung Typ AS

als Abbrechstift

Anti-skid type AS

knock off stud

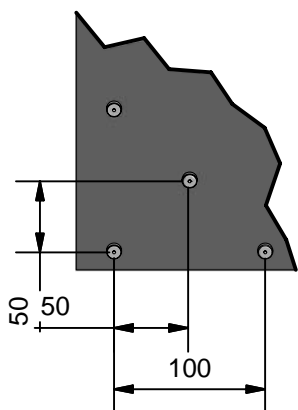
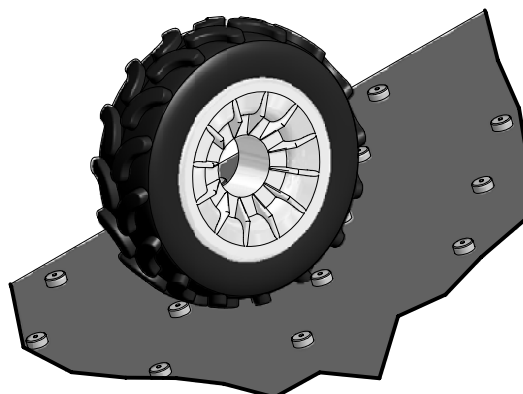
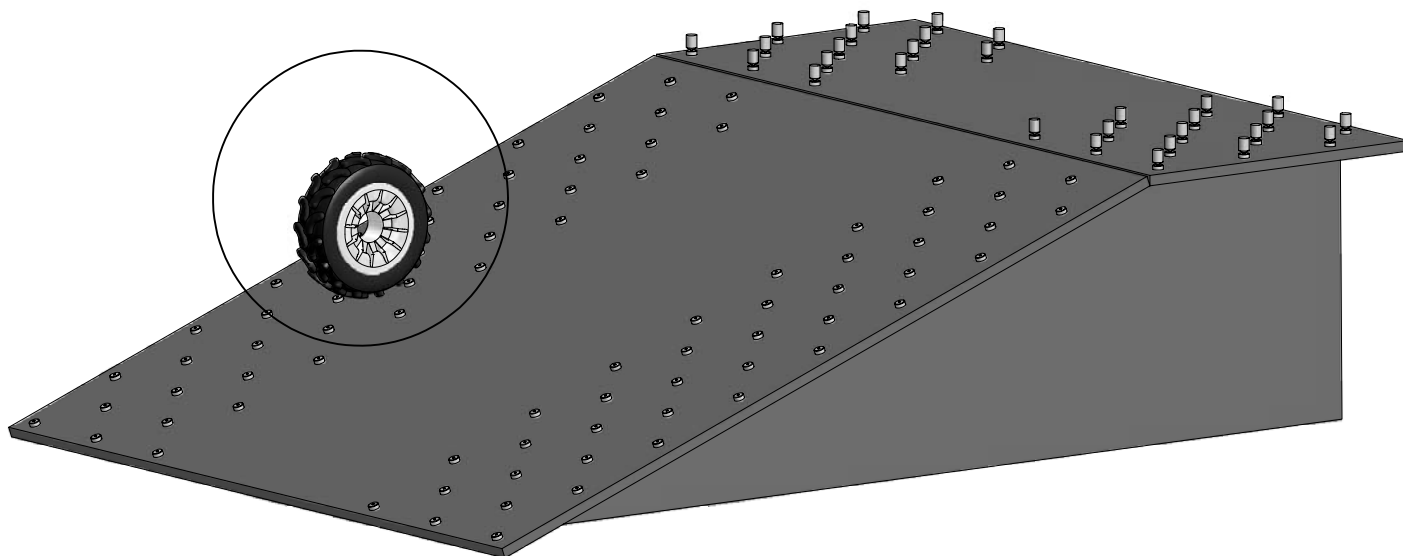

- hohe Traktion
- Unfallsicherheit
- lange Standzeiten
- kein Verziehen
- keine Nachbearbeitung
- problemlose Nachrüstung
- leichte Reinigung

- high traction
- less risk of accident
- long life
- no head-influence in the ramp
- no afterwork conservation on the backside
- easy repairing with ship-crew
- easy cleaning

Rutschsicherung Typ AS
als Abbrechstift

Anti-skid type AS
Knock off stud

Vor dem schweißen >>>>schweißen und abbrechen>>>>
before welding >>>>welding and to knock off>>>>

Nach dem schweißen
after welding

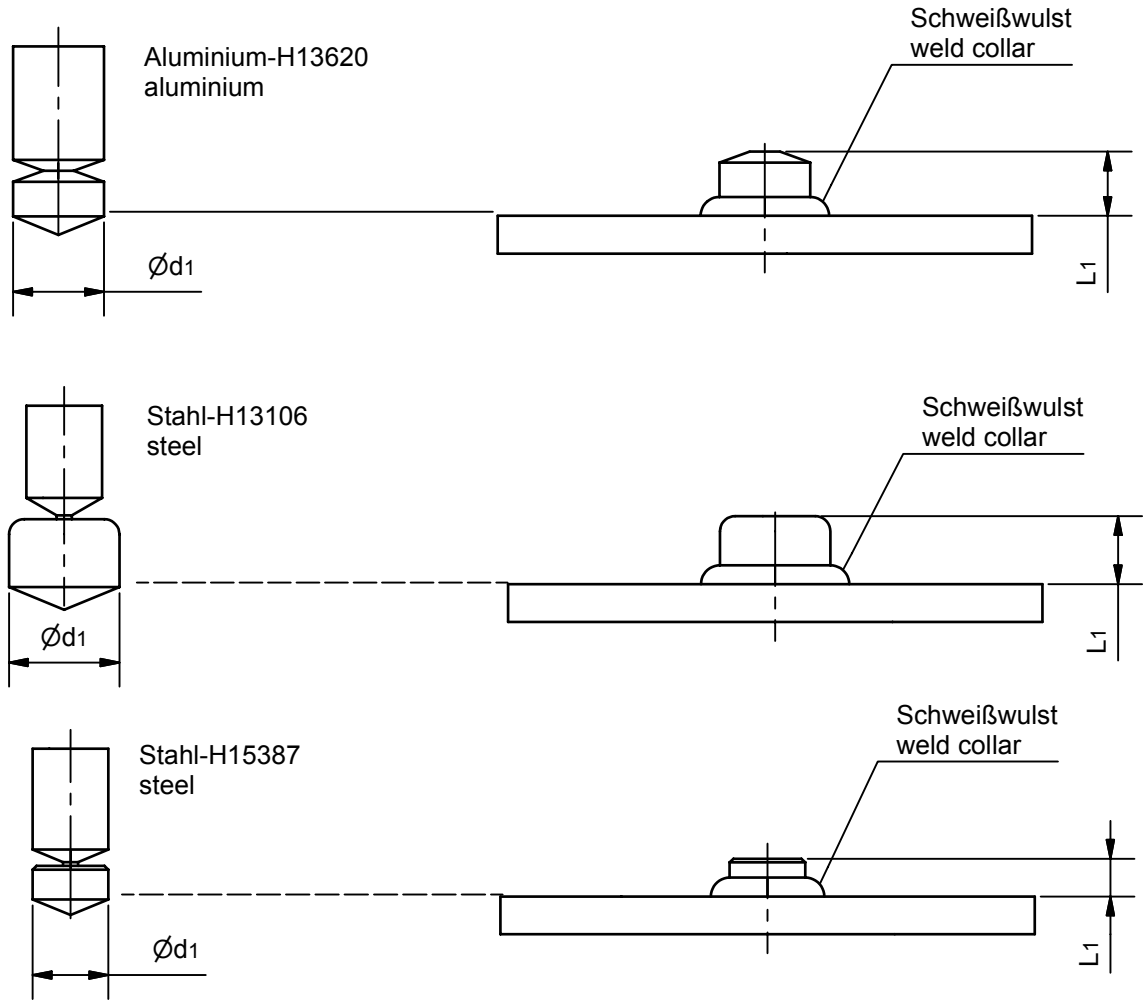

Bezeichnung description	Bestell-Nr. art.no	Abmessungen measurement		Material material
		d1	L1	
AS-Al / 12x8,5	H 13 620	12	8,5	Aluminium aluminium
AS-St / 14,6x9	H 13 106	14,6	9	Stahl steel
AS-St / 10x5	H 15 387	10	5	Stahl steel